

FLYING ELEVEN NATIONAL CHAMPIONSHIPS 2010



10th -16th January 2010
Tamar Yacht Club
Beauty Point, Tasmania

SAILING INSTRUCTIONS

1 RULES

- 1.1 The regatta will be governed by the rules as defined in the Racing Rules of Sailing 2009-2012, the YA Special Regulations, Part 2, 2009 – 2012, and the rules of the Flying Eleven Sailing Association of Australia, except as any of these are altered by the Notice of Race or these Sailing Instructions.
- 1.2 Only 1 set of sails, 1 centreboard, 1 rudder and 1 mast shall be allowed to be used during the regatta, unless written approval has been obtained from the race committee following loss or damage.

2 NOTICES TO COMPETITORS

Notices to competitors will be posted on the official notice board located in the club house.

3 CHANGES TO SAILING INSTRUCTIONS

Any change to the sailing instructions will be posted before 0900hrs on the day it will take effect, except that any change to the schedule of races will be posted by 2000hrs on the day before it will take effect.

4 SIGNALS MADE ASHORE

- 4.1 Signals made ashore will be displayed on the flag mast .
- 4.2 When flag AP is displayed ashore, '1 minute' is replaced with 'not less than 30 minutes' in the race signal AP.

5 SCHEDULE OF RACES

- 5.1 Dates of racing:
- 10 January Measuring and Invitation Race
 - 11 January Race Day
 - 12 January Race Day
 - 13 January Reserve Day
 - 14 January Race Day
 - 15 January Race Day
 - 16 January Race Day and Presentation
- 5.2 The scheduled time of the warning signal for the first race each day is 1330hrs.
- 5.3 After a long postponement, to alert boats that a race or sequence of races will begin soon, an orange flag will be displayed for at least four minutes before a warning signal is displayed. A single sound signal shall draw attention to the orange flag.
- 5.4 On the last day of the regatta no warning signal will be made after 1530hrs.

6 CLASS FLAGS

The Class flag is the Flying Eleven class flag, which has a blue Flying Eleven insignia on a white background.

7 RACING AREAS

Attachment A shows the location of racing areas.

8 THE COURSES

- 8.1 The diagrams in Attachment B show the courses, including the approximate angles between legs, the order in which marks are to be passed, and the side on which each mark is to be left.
- 8.2 The course to be sailed will be displayed by a numeral pennant on the race committee vessel prior to the warning signal

9 MARKS

- 9.1 Marks 1, 2, and 3 will be orange cylinders.
- 9.2 The new mark, as provided in instruction 13.1, will be an orange inflatable with a black horizontal band.
- 9.3 The starting mark will be a boat with an orange flag.
- 9.4 The finishing mark will be a buoy with an orange flag

10 THE START

- 10.1 The starting line will be between a staff displaying an orange flag on the race committee boat on the starboard end and the start mark at the port end.
- 10.2 A boat starting later than 4 minutes after her starting signal will be scored Did Not Start. This changes rule A4.1.

12 CHANGE OF THE NEXT LEG OF THE COURSE

To change the next leg of the course, the race committee will lay a new mark (or move the finishing line) and remove the original mark as soon as practicable. When in a subsequent change a new mark is replaced, it will be replaced by an original mark.

13 THE FINISH

The finishing line will be between a staff displaying an orange flag on the race committee boat on the starboard end and the finish mark at the port end.

14 TIME LIMITS

- 14.1 The time limit for each race shall be two hours
- 14.2 Boats failing to finish within 20 minutes after the first boat sails the course and finishes, or within the time limit, whichever is latest, will be scored Did Not Finish without a hearing. This changes rules 35 and A4. and A5.

15 PROTESTS AND REQUESTS FOR REDRESS

- 15.1 Protest forms will be available at the race office. Protests shall be delivered there within the protest time limit.
- 15.2 The protest time limit is 60 minutes after the last boat has finished the last race of the day. The same protest time limit applies to all protests by the race committee and to requests for redress. This changes rules 61.3 and 62.2.
- 15.3 Notices will be posted within 30 minutes of the protest time limit to inform competitors of hearings in which they are parties or named as witnesses.
- 15.4 For the purpose of rule 64.3(b) the 'authority responsible' is the measurer appointed by the organising authority.
- 15.5 Breaches of instructions 17, 19, 20, 22, 24, 25 and 27 will not be grounds for a protest by a boat. This changes rule 60.1(a).
- 15.6 On the last day of the regatta a request for reopening a hearing shall be delivered:
 - (a) within the protest time limit if the party requesting reopening was informed of the decision on the previous day;
 - (b) no later than 30 minutes after the party requesting reopening was informed of the decision on that day. This changes rule 66.

16 SCORING

- 16.1 The scoring system is as follows: Low Point Score System, Appendix A
- 16.2 Four races are required to be completed to constitute a series.
- 16.3 (a) When fewer than five races have been completed, a boat's series score will be the total of her race scores.

- (b) When from five to seven races have been completed, a boat's series score will be the total of her race scores excluding her worst score.

17 SAFETY REGULATIONS

17.1 Check-Out and Check-In:

The helmsperson of each boat shall 'check-out' with the tags provided for the purpose prior to each race and "check-in" with the same tag after each race, except that, if races are sailed "back to back", 'check-out' shall be done before the first, and 'check-in' after the last of the races sailed back to back. 'Check-in' is to be completed within 60 minutes of the last boat finishing.

- 17.2 A boat that retires from a race shall, where possible, notify a race official boat and "sign off" as soon as possible on reaching the host club.

18 REPLACEMENT OF CREW OR EQUIPMENT

- 18.1 Substitution of competitors will not be allowed without prior written approval of the race committee

- 18.2 Substitution of damaged or lost equipment will not be allowed unless authorized by the race committee. Requests for substitution shall be made to the committee at the first reasonable opportunity.

19 EQUIPMENT AND MEASUREMENT CHECKS

A boat or equipment may be inspected at any time for compliance with the class rules and sailing instructions. On the water, a boat can be instructed by a race committee equipment inspector or measurer to proceed immediately to a designated area for inspection.

20 ADVERTISING

Boats may be required to display advertising supplied by the organizing authority.

21 OFFICIAL BOATS

Official boats will be marked as follows:

Display of the F11 Class Burgee.

22 SUPPORT BOATS

Team leaders, coaches and other support personnel shall stay outside areas where boats are racing from the time of the preparatory signal until all boats have finished or retired or the race committee signals a postponement, general recall or abandonment, unless exception is granted by express authority from the Race Committee.

23 TRASH DISPOSAL

Boats shall not put trash in the water. Trash may be placed aboard support and race committee boats.

24 RADIO COMMUNICATION

No boat shall make nor receive electronic communications or use electronic navigation or tactical aids while racing. This restriction also applies to mobile phones.

25 DISCLAIMER OF LIABILITY

Competitors participate in the regatta entirely at their own risk. See rule 4, Decision to Race and Condition of Entry documentation. The organizing authority will not accept any liability for material damage or personal injury or death sustained in conjunction with or prior to, during, or after the regatta.

26 INSURANCE

All helmspersons shall have third party insurance cover of not less than \$10,000,000 for any accident.

All owners/competitors who sign the Entry Form are deemed to have made a declaration that they hold such cover. Competitors may be required to produce evidence of such insurance and any competitor not holding this cover shall withdraw their entry.

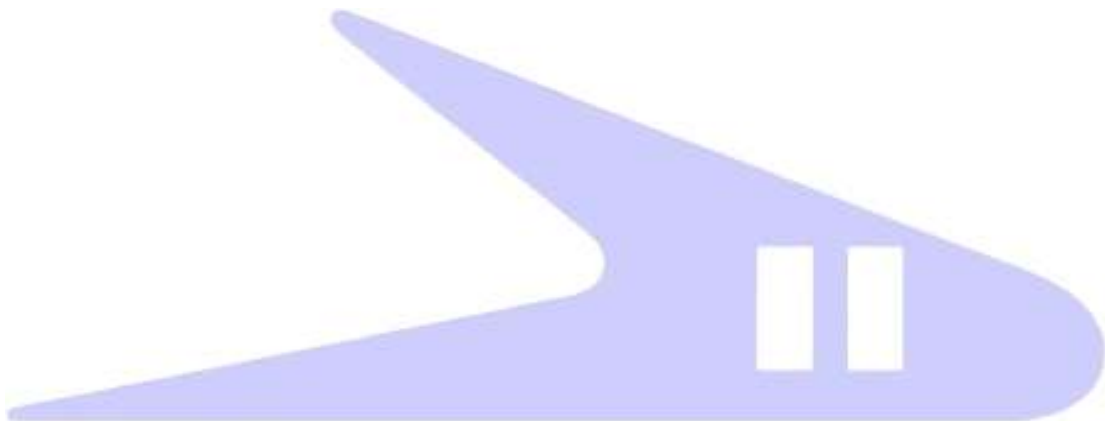

ATTACHMENT A



ATTACHMENT B

COURSES

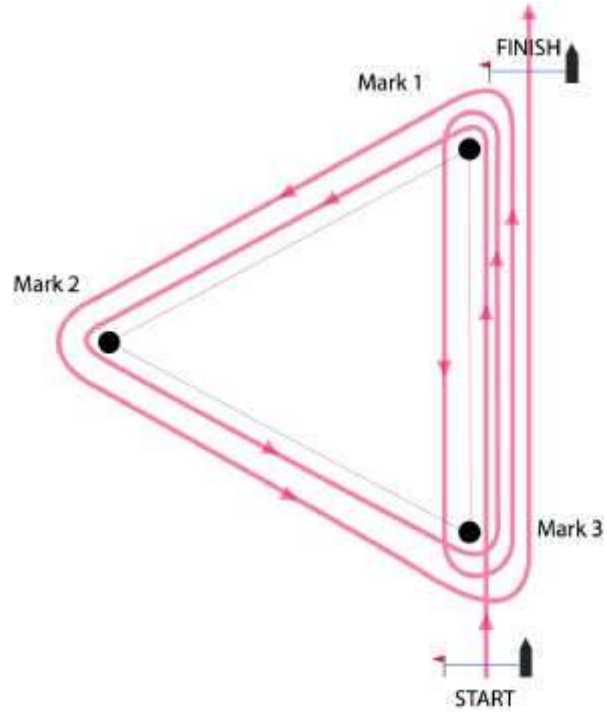

COURSE No.1 – Port Rounding

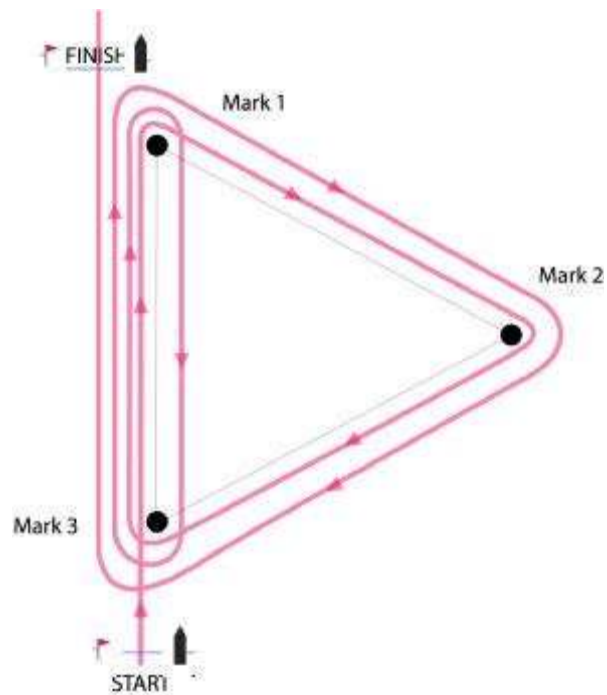

COURSE No.2 – Starboard Rounding